

BERTH RENTAL TERMS & CONDITIONS

1. BERTH RENTAL

- 1.1 The Marina Management grants a rental agreement to the Berth Occupier as named in the Berth Rental Agreement to occupy the berth specified for the period stated and at the rate stated. The Berth Occupier agrees to accept the rental agreement under the **following** terms and conditions.

2. THE FULL AGREEMENT

- 2.1 The full agreement and terms between the Marina Management and the Berth Occupier is contained within the:
- 2.2 Berth Rental Agreement
- 2.3 Berth Rental Terms & Conditions
- 2.4 Any other documents published or administered by the Marina Management or its duly authorised employee or agent for the purpose of managing the marina.

3. COMMENCEMENT

- 3.1 The agreement commences upon the start date stated in the Berth Rental Agreement and remains in effect until terminated by either party giving the required notice as stated in the Berth Rental Agreement.

4. RENT

- 4.1 The Berth Occupier agrees to pay rental of the berth to Marina Management at the rental rate set out in the Berth Rental Agreement or as may be amended from time to time. Marina Management may alter the rental rate by the giving of one month's written notice of the revised rental rate.
- PLEASE NOTE:** When your boat is out on the hardstand and or away from the berth at any time and you wish to retain that berth, you will still be charged as if your boat is still on that berth.

5. TERMS OF PAYMENT

- 5.1 All fees must be paid by the 20th of the month following date of original invoice. Any fees accumulated at time of vacating Marina must be settled in FULL. For online payments use your customer A/C No or your Invoice No. as a reference
Payee -Tauranga Marina Society Inc. 03 0435 0540516 00.
IF FEES ARE NOT PAID BY THE DUE DATE YOU MAY BE LIABLE FOR INTEREST AND DEBT COLLECTION FEES ON ALL OVERDUE ACCOUNTS.

6. JURISDICTION

- 6.1 When a Berth Occupier enters the marina premises the Berth Occupier and those persons accompanying the Berth Occupier are subject to the jurisdiction, terms and conditions outlined in clause 2 above.
- 6.2 When a pleasure craft owned or under the control of the Berth Occupier enters the marina then the vessel and its occupants are subject to the jurisdiction, terms and conditions as outlined in clause 2 above.

7. PURPOSE OF OCCUPATION

- 7.1 The Berth Occupier shall only use the berth for pleasure boating purposes and not for any commercial or other use or purpose unless the Marina Management at its sole discretion has approved such a use.



BERTH RENTAL TERMS & CONDITIONS

8. MAXIMUM DIMENSIONS OF BOAT

- 8.1 The Berth Occupier shall at no time allow any part of any vessel using or moored in the berth (including spars, bowsprits, anchors davits and tenders or any other thing affixed to the vessel) to exceed the published or nominal dimensions of the berth. For avoidance of doubt, the published or nominal dimensions are less than the physical dimensions of the berth and indicate the maximum dimension of an occupying vessel.
- 8.2 The Berth Occupier, for further guidance is referred to the diagram and explanation on the reverse of the Berth Rental Agreement.

9. CHANGE IN NOMINATED VESSEL

- 9.1 The Berth occupier shall ensure that if the vessel nominated on the Berth Rental Agreement changes that:
- The new proposed vessel fits the dimensions of the berth as listed on the Berth Rental Agreement: and
 - Marina Management is advised of change in vessel before it occurs.

10. VISITORS TO THE MARINA

- 10.1 The Berth Occupier shall ensure that:
- All of its invitees comply with the terms of this Agreement; and
 - Any children under the age of 13 and for whom the Berth Occupier or its visitors are responsible, are accompanied by an adult.

11. SUBLETTING OF BERTH

- 11.1 No Berth Occupier can sublet their berth.

12. POWER AND OTHER SHORE SERVICES

- 12.1 The Berth Occupier shall ensure that any use of power, water, sewage, pump or other shore service, complies with all of the relevant regulations and rules governing the supply or discharge of power, water, sewage, or other shore services.

An Electrical Warrant of Fitness (EWOFF) is required for every vessel, whether your vessel is wired for 240V or 12V. “The Number One rule is that if you take power from the Marina you must have an EWOFF. Be it to supply a hard-wired 240 volt installation or an unattended lead supplying **ANY** appliance. **This includes (but not limited to) for example, a chiller, deep-freeze, humidifier, transformer, battery-charger, lights, alarms etc.”**

13. WATER SPACE AND ACCESS RIGHTS

- 13.1 This rental agreement relates only to the allocated water space of the berth. In common with others, the Berth Occupier should have the right to tie up to the allocated berth structures and should have the right to access in, and the use of, the common waterways and pathways of the Marina area subject to such rules at to access and during such hours as the Marina Management may specify for the safety security and preservation of good order.

14. CONTRACTOR ACCESS

- 14.1 The Berth Occupier must ensure that any contractor or tradesman invited in to the marina complex for the purpose of carrying out work on the Berth Occupiers vessel, holds sufficient insurance to satisfy Clause 15.



BERTH RENTAL TERMS & CONDITIONS

- 14.2 The Berth Occupier is responsible for ensuring that any Contractor invited into the Marina Complex has in accordance with the Marina's Health and Safety Policy completed a Contractor Access Application Form.
- 14.3 The Berth Occupier indemnifies and will keep indemnified the Marina Management against all actions, suits, claims, debts, obligations and other liabilities arising out the activities of any contractor invited by the Berth Occupier to work on the Berth Occupiers vessel.

15. RESTRICTED ACTIVITIES

- 15.1 The Berth Occupier shall at all times comply with the rules as outlined in this agreement in addition to any published rules issued by or any special instructions issued by the Marina Management.
- 15.2 The Marina Management may vary the rules by written notice to Berth Occupier. If there is any inconsistency between the provisions of these terms and conditions and the Berth Rental Agreement, the provisions of the Berth Rental Agreement shall prevail.

16. INDEMNITY

- 16.1 The Berth Occupier shall indemnify the Marina Management against any loss, expense, legal liability, claims and costs incurred by the Marina Management arising as a result of the Berth Occupiers act or omissions or the acts or omissions of others to which the Berth Occupier has contributed or than acts or omissions of any person invited into the Marina by the Berth Occupier.

17. INSURANCE

- 17.1 The Berth Occupier shall throughout the term of this agreement keep all of the Berth Occupiers vessel(s), equipment and other property in the Marina fully insured against loss or damage by any reason and or/other usual maritime risks. **Your Insurance must include no less than 5 million 'Liability Insurance'.**
- 17.2 The Berth Occupier shall, if requested by the Marina Management, provide copies of the policies affected pursuant to this clause together with a certificate of currency for such policies.

18. DAMAGE TO MARINA PROPERTY

- 18.1 The Berth Occupier will be responsible for all damage to all Marina Property including docks, structures, pilings or property in the marina and or vessels and persons using the marina arising from any act or omission, neglect or default by the Berth Occupier or its agents, servants, contractors, employees or invitees relating to the use, storage of the vessel.

19. ABANDONED, UNSEAWORTHY OR ILL-REPAIRED VESSELS

- 19.1 The Berth Occupier shall keep any vessel occupying the berth in good serviceable condition and repair so as not to obstruct, interfere with or endanger other vessels navigating or berthed in the Marina.
- 19.2 Should the Berth Occupier fail to comply sub-clause 17.1, the Marina Management may, serve a default notice on the Berth Occupier requiring the Berth Occupier to remedy specified areas in default within a reasonable period of time.
- 19.3 If the Berth Occupier fails to comply with a default notice issued under clause 17.2 within the time specified, the Marina Management may at its total discretion invoke the claim procedure as outlined in clause 6 of this agreement.



BERTH RENTAL TERMS & CONDITIONS

20. EMERGENCY MANAGEMENT

- 20.1 The Marina Management reserves the right to use the berth in the case of an emergency and also require the Berth Occupier to vacate the berth if necessary to allow urgent repairs to be carried out. In such circumstances the Marina Manager may with his best endeavours, but shall not be obliged to, provide an alternative berth.
- 20.2 In extreme emergencies, the Marina Manager reserves the right to take whatever steps are required to ensure the integrity of the marina facility. The Marina Management's judgement in this respect is actioned at their sole discretion.

21. TERMINATION & CLAIMS PROCEDURE

- 21.1 If the Berth Occupier at any time fails to pay the Marina Management the rental fees and charges due under this agreement or is otherwise in breach of any of the terms, conditions and provisions herein, and such breach shall continue for the space of 7 days after notification of the breach has been given sent to the address recorded in the Berth Rental Agreement then the Berth Occupier's right to occupy the berth pursuant to the Berth Agreement shall terminate upon expiry of such notice and the further provisions of this clause shall become applicable and may be enforced by the Marina Management PROVIDED THAT the Berth Occupier shall remain liable for payment of rental fees and other charges until the vessel is removed for the Marina.
- 21.2 On the termination of this agreement the Berth Occupier shall promptly remove the vessel and all goods and effects of the Berth Occupier from the marina and in default of the Berth Occupier so doing, the Marina Management shall be entitled to invoke the claim procedure as outlined below.
- 21.3 If the Berth Occupier defaults under this agreement or is terminated under Clause 17, the Marina Management may at its total discretion, serve a default notice on the Berth Occupier by posting the same to the Berth Occupier's given address or alternatively affixing the default notice in a prominent position to the vessel requiring the Berth Occupier to within 28 clear days.
- 21.4 Should the Berth Occupier fail to comply with the default notice within the time specified in the notice, the Marina Management may (but without any obligation to do so) without further notice remove any vessel occupying the berth and recover the cost of removal from the Berth Occupier.
- 21.5 Where the Marina Management removes any vessel in accordance with this clause, it shall be entitled to a lien on the vessel to the extent of the costs of removal and storage.
- 21.6 Should the Berth Occupier fail to remedy the default to the satisfaction of Marina Management within 28 days after date of such removal, the Marina Management may, at any time thereafter, offer the vessel for sale by public auction or private contract and apply such of the proceeds of any resulting sale first in satisfaction of the Marina Management's expenses incurred in the removal and storage including administrative expenses and the cost of providing custodians, secondly in towards satisfaction of any debts or liabilities owed by the Berth Occupier to the Marina Manager and thirdly to the Berth Occupier.
- 21.7 The Berth Occupier hereby irrevocably appoints the Marina to be the attorney of the Berth Occupier to execute all documents and to do all things as are necessary to give effects to such sale.

22. BAILMENT

- 22.1 The terms of this agreement are not in any way intended by either party to create a bailment and the Berth Occupier understands that the Marina Management accept no responsibility for the care of any vessel and its contents.



BERTH RENTAL TERMS & CONDITIONS

23. PRIVACY ACT DISCLOSURE

23.1 The Berth Occupier hereby authorises the Marina Management to upon default or termination of this agreement disclose to the membership of the Marina Operators Association of NZ Inc any personal information held by the Marina Management about you.

PART II – DEFINITIONS

“**Berth**” means the berth in the Marina as described in the Berth Rental Agreement.

“**Berth Occupier**” means the person or entity named in the Berth Rental Agreement.

“**Commencement Date**” means the date specified in the Berth Rental Agreement.

“**Default rate**” means the Marina Managers bank overdraft interest rate plus a further 4% per annum.

“**Facilities**” means the foreshore areas, parking areas, driveways, landscaped areas, toilets, launching ramp and other facilities constructed or placed on, or in, the Marina Area.

“**Marina**” means the relevant marina facility in which the Berth Occupier is keeping a vessel or interest and includes the Marina Structures, access ways, all facilities and services.

“**Marina Management**” means the body appointed to run the Marina business and to bind the Marina in its legal affairs and includes its successors and assigns.

“**Marina Rules**” means the rules established by the Marina Management as contained in this agreement and those published and updated by the Marina Management from time to time.

“**Nominated Vessel**” means the vessel specified in the Berth Rental Agreement. Details or any other vessel nominated by the Berth Occupier by notice in writing to the Marina Management.

“**Services**” means the power, water and any other services provided for the benefit of the Berth Occupier in the Marina.

“**Structures**” means the breakwater, fingers, jetties, fuelling jetty, loading jetty, piles and other structures constructed or placed on or in the Marina Area.

“**Term**” means the period commencing on the Commencement Date and ending on the Termination Date.

“**Termination Date**” means the date specified in the Berth Rental Agreement, or a date specified in a notice to terminate this agreement giving the required written notice period as described in the Rental Agreement.

“**Working Day**” means any day of the week other than; (a) Saturday, Sunday, Good Friday, Easter Monday, Anzac Day, the Sovereign’s Birthday, Labour Day, Waitangi Day and Auckland Anniversary; and (b) a day in the period commencing with 24 December in any year and ending 5 January in the following year. A working day shall be deemed to commence at 9.00am and terminate at 5.00pm.

“**Boat Length**” to mean the Extreme Length of boat including all appendages and attachments:



BERTH RENTAL TERMS & CONDITIONS

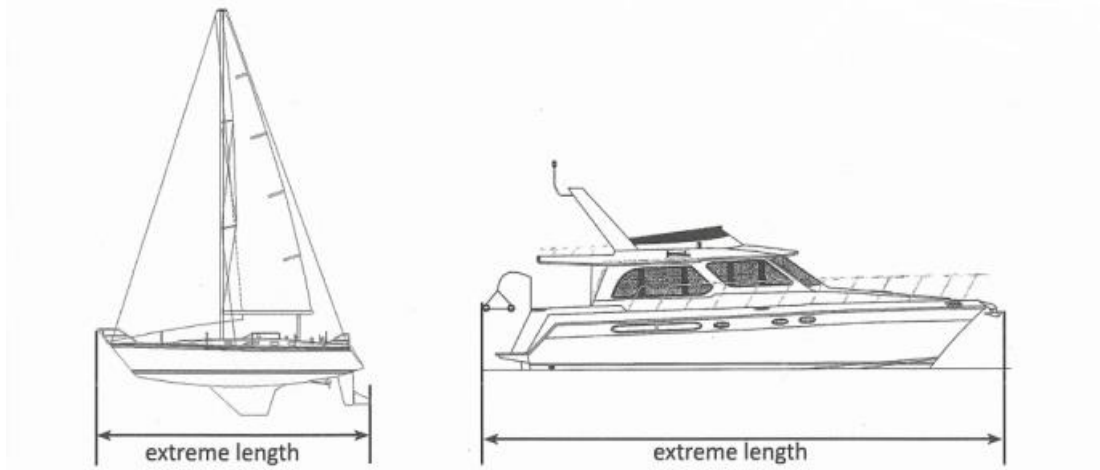

EMERGENCY SERVICES

Fire / Ambulance / Police 111

Marina Office 07 578 8747

National Poisons Centre 0800 764 766

BOP Regional Council

Pollution Hotline 0800 884 883

Tauranga Harbourmaster 0800 884 880

Tauranga Coastguard 07 578 5579

TAURANGA MARINA SOCIETY INC

PO Box 690 | Tauranga 3144

45 Keith Allen Drive | Sulphur Point | Tauranga 3110

Ph: 07 578 8747 Fax: 07 578 4600

manager@taurangamarina.co.nz

